

Keeping them Honest...

1098 Maintenance Costs Exposed: What you don't know will cost you.

At Bikeland and 1098Desmo.com we're always looking out for your best interests. When we heard that Ducati North America (DNA) had improved their manufacturing tolerances we were excited... excited to hear the their bikes previously renowned to require a lot of service now needed up to 50% less service. With lower MSRPs and 50% less maintenance, DNA is hoping to convert Sportbike riders who frequent the Big Four and get them riding Red.

How does this translate to the real world? In December 2006, Ducati sent a bulletin to its dealer network outlining the new, lower service costs for their motorcycles – costs which go hand in hand with DNA's marketing campaign highlighting lower maintenance as a major selling feature of their products.

The introduction of the bulletin reads:

"Dear Service Manager,

This is to inform you that Ducati Motor Holding has changed the service maintenance program starting with the MY 2007 production motorcycles. All 2007 Maintenance Schedules will be posted online at www.ducatusa.com in the Dealer Only area under MRP/Service.

There appears to be some confusion regarding the service intervals on all MY 2007 models. Ducati Motor Holding has extended by 25% the maintenance service intervals giving us an opportunity to change the customer perception that our product is "high maintenance". In order to achieve such goal it is very important that all Ducati dealers will cooperate by applying to all 2007

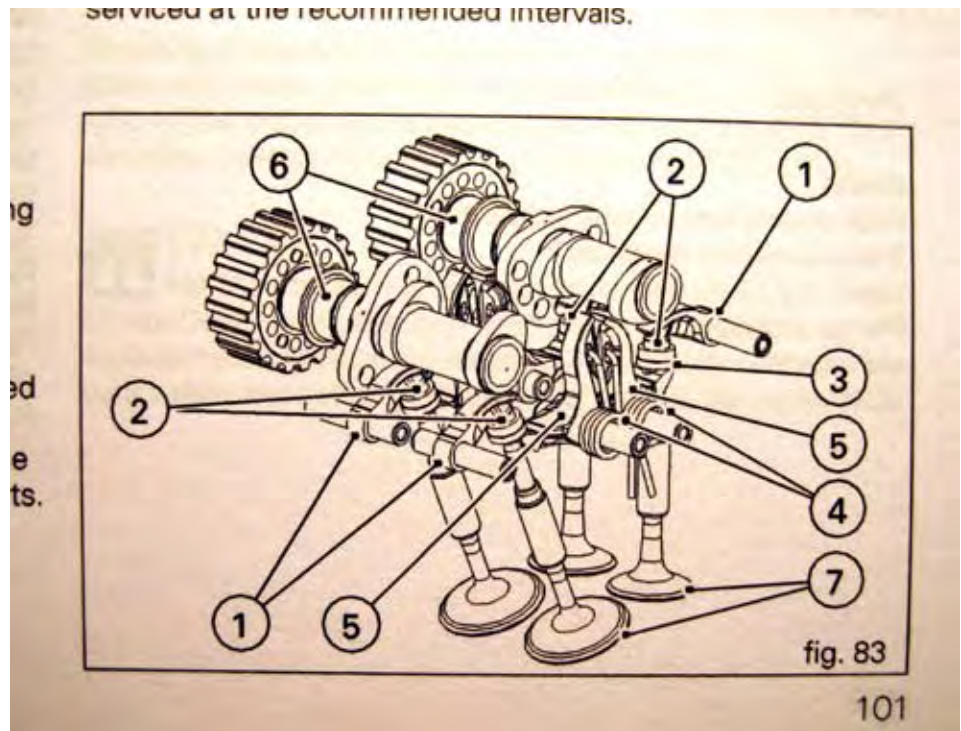

customers the lower maintenance cost recommended by the factory.

Ducati North America is expecting some variability in what the dealers are charging for scheduled maintenance based on individual labor rates, but in order to change the customers perception of high maintenance it is very important that all dealers will follow the factory guide lines that is reflecting a substantial reduction in parts and labor cost from the MY 2006 services."

Ducati's marketing material contains this bold statement:

"50% less maintenance cost on every 2007 Ducati

We are proud to announce that all 2007 Ducati models require less frequent service, fewer parts and less labour during each service and, as a result, greatly reduced scheduled maintenance costs – by as much as 50%. Reducing the cost of service when you visit your Ducati Dealer for maintenance is one way to measure the new quality of Ducati. It also contributes immensely to making the Ducati ownership experience as satisfying as the Ducati riding experience. Research and

development is the number one investment at the Ducati factory. This investment in performance and quality includes our factory processes, machinery and the people who build each Ducati. By 'engineering-in' quality through design, materials and testing, every Ducati owner will enjoy significant and quantifiable improvements in every Ducati motorcycle. To a rider, the best measure of quality is the riding experience. You can feel a new smoothness to the legendary Ducati L-Twin, a more progressive nature to the powerful brakes and more confident road holding in every turn. Reliability and quality – one ride is all the proof you will need.

50% less – 100% Ducati. Standard equipment in every 2007 model."

Fast forward to April of 2007. The 1098's have hit the roads and pretty soon it will be service time. Bikeland just took delivery of our long term 1098 test unit, but since it's raining outside we had an afternoon to kill, so we sat down with pen in hand to find out what a first service would cost Joe Average.

DNA specifies one hour for the first service on their new flagship bike...

operations to be carried out by the dealer

| km x1000 | 1 | 12 | 24 | 36 |
|-------------|-----|-----|----|------|
| miles x1000 | 0,6 | 7,5 | 15 | 22,5 |
| Months | 6 | 12 | 24 | 36 |
| | • | • | • | • |
| | • | • | • | • |
| | | | • | • |
| | | | • | • |

gone is the expensive and time-consuming belt adjustment. According to the maintenance bulletin, for its first stop in the shop Ducati says the 1098 requires an oil & filter change, a chain adjustment and a check of the brake and clutch fluid. The dealer is to road test the bike. Total parts required – oil, filter and the crush washer for the drain plug, and one hour's labor for a maximum 1st service cost of \$144.38 set by Ducati (with a small margin allowed for varying labor rates).

Armed with this information in hand, Bikeland cold called 13 dealers across the US and Canada to see what Joe Average was really being charged and this is what we found...

We started with north of the border and called two Ducati dealers in Canada – Richmond Motorsports and John Valk. Both shops quoted us higher than expected service charges. Richmond told us that it would take two hours for the service and told us that they would complete a fastener check and some additional adjustments. The total charge - \$250.

They told us that they felt that there was more service required for the Ducati than what DNA recommended. When we pointed out that DNA only called for a one hour service, they had no problem with going by the book

although they insisted they would not adjust the chain (included in the one hour service set out by Ducati).

John Valk gave us a different story. According to this dealer the service would take three and a half hours and set you back a minimum \$400. When we pointed out that the service was only supposed to take one hour, they told us that their mechanic took a lot longer than one hour to do the work required and we would be on the hook for the bill.

Then we headed south of the border, starting with Skagit Powersports, nine times in the Dealer News Top 100. The service department of Skagit Powersports told us that it would be \$245 labor plus parts charges. When we asked if they were aware that DNA only required a simple oil change, they became extremely upset and told us that they weren't "ripping people off", then they hung up on us.

When we called Skagit back to inform them that they had been part of a price checking test, they emailed us and told us that after our call informing them they were part of a test, they checked the rates and determined that we were correct, and it really only did

take one hour. They went on to defend themselves by claiming that their service agent didn't have access to the book when he gave the quote – it sure seemed like he knew what he was talking about when he was yelling at us telling us we were wrong!

Jim from Skagit Powersports told Bikeland that it was difficult for them to be aware of the actual maintenance costs since they "carry nine different brands of motorcycles, quads, and water craft. So there is no way to remember them all".

Maybe Jim should take a walk into his showroom and look at all those Ducati brochures they have clearly stating 50% less service is required on the 2007 product.

Heading into Oregon, we found our first two honest Ducati dealers... random calls to Salem Ducati and Bend Euro Moto were impressive. Both dealers flat out told us that the first service was only one hour – that the only parts required were oil, filter and the washer, and proudly promoted the fact that Ducati's now required far less service than before!

The call to Dunbar Euro-Sports in Massachusetts netted two quotes. The first quote was three to four hours... after being left on hold, they returned with their final answer of two hours. The two-hour quote included a fastener check and would cost \$250. When we informed them that we knew about DNA's recommended one-hour service for this bike, the folk at Dunbar begrudgingly offered to do exactly what Ducati recommended they do.

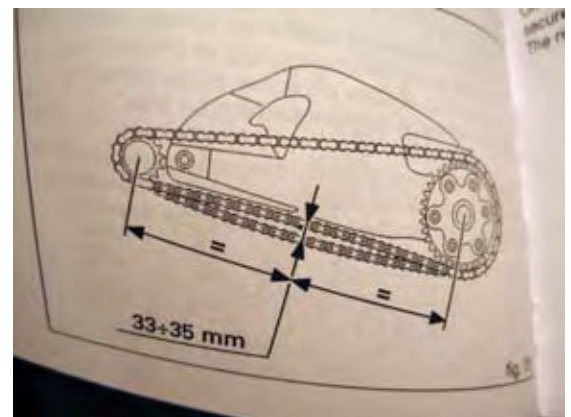

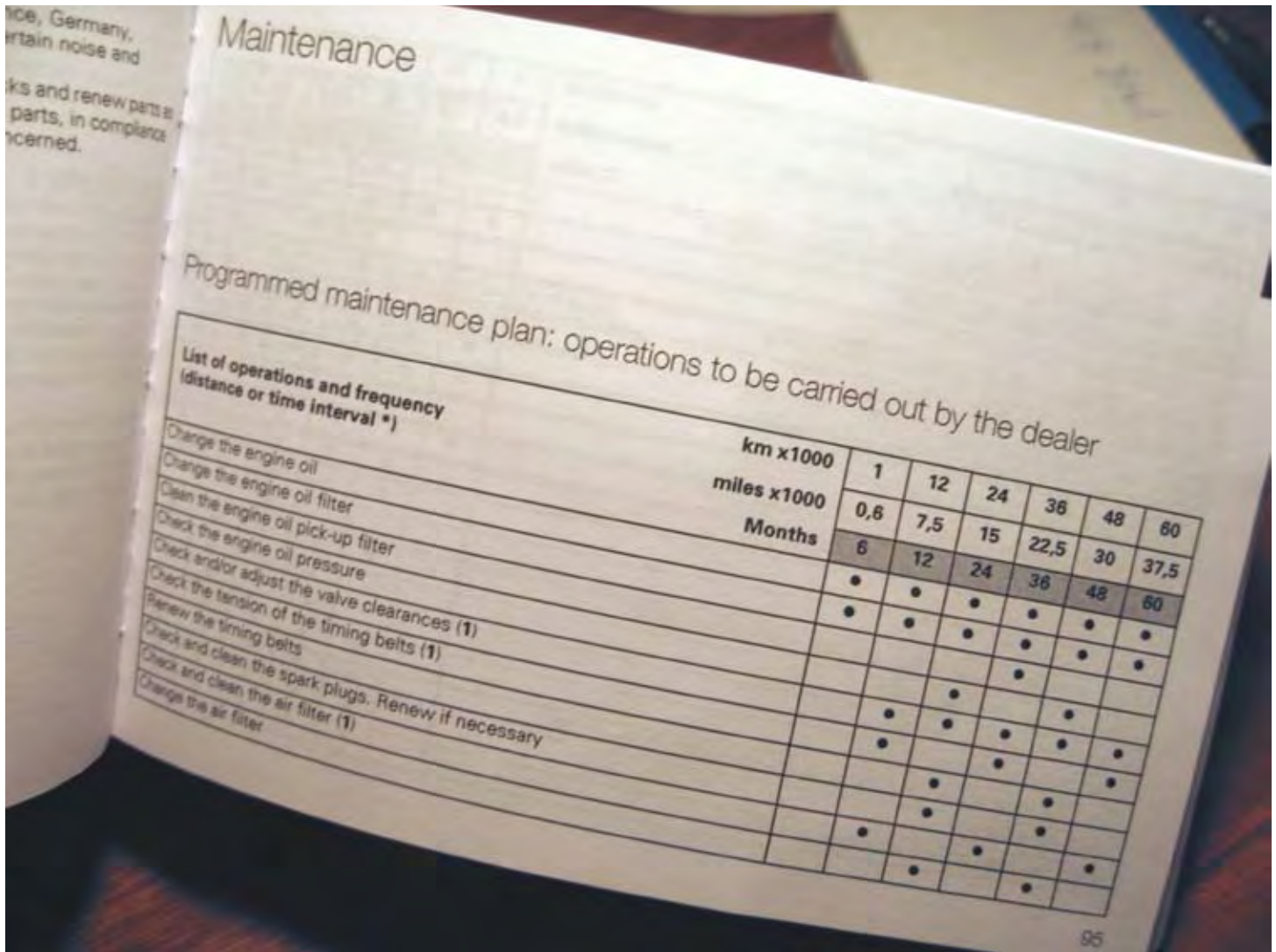

Great Bay Motorcycles in New Hampshire told us that the 1098 required a belt tension check (not required by DNA) and it would cost us \$80/ hour for three and a half hours of their time - plus materials.

Next on the list was Gengras Ducati in Connecticut where we find our third honest dealer. Gengras told us it would only take one hour for the service, pointed out that Ducati's now needed less service and were happy to inform us that the bike only required the oil change and anything else wrong with the bike (ie: loose steering bearings etc) would be covered under warranty.

New Jersey's Jack Trebour Motorcycles was close, but no cigar. They quoted us an hour and a half, telling us that the bike needed the clutch and the brakes to be bled.

In Florida, Florida Sports Cycle &

Marine hit us up with the now apparently standard hour and a half charge - one hour for Ducati, add a half for the "vig".

We found another honest dealer shows up in Tucson, Arizona - Renaissance Motorcycles. Bill diligently informs us that Ducati's now require less maintenance, and that the first service is only one hour! Bill from renaissance tells us he quotes "by the book"... and he actually does! Imagine that!

Now we head over to California, and we find Modesto Ducati with a quote of one and a half hours for the first service, part of which includes clearing the "service" display from your dashboard... probably an extra half hour's worth of work in that, wouldn't you agree?

That's a bargain compared to Monterey Peninsula Sports.

Located only a short drive from Ducati North America's headquarters, Jeff from this dealership knows a lot more than the OEM does. He informs us that the 1098 needs a three and a half hour service. When the one hour recommended service is pointed out to him, Jeff tells us that the people he's talked to in Ducati service say "you should check the belts" and that waiting to check them until the recommended 7500 miles is "too long" and that the 1098's he's checked have had loose belts already.

When we again tell him that DNA recommends one hour, he told us "Ducati says one hour but the reality is it takes longer" - at least two hours for the minimum service he points out.

Is this an issue of honesty, price gouging or simply a lack of education on the part of Ducati dealers? We're not sure - but from a consumer's standpoint it doesn't

really matter. It comes down to this: when you're marketed a vehicle that requires less maintenance as a selling feature and your told so repeatedly in marketing campaigns, what on Earth would prompt the OEM's dealer network to work to the contrary of this?

From a consumers standpoint you can only draw one of two conclusions:

1 - The OEM isn't being straight forward and a Ducati really does need more service than they claim (ie: the dealer knows better than the OEM)

2 - The Dealers want more of your money and they don't care if they require less service... they're going to charge you whatever they want... too bad for you.

Of the 13 dealers we contacted, only 4 of them charge what Ducati recommends you pay for servicing your 1098 and only 2 of them offered you a choice of how much service you wanted.

The four dealers that bill by the book are Bend Euro Moto, Salem Ducati, Gengras Ducati and Renaissance Motorcycles.

The two dealers who allow you to have either the recommended service, or pay for additional adjustments they felt necessary are Richmond Motorports and Dunbar Euro Sports, however (and this is a big however) they only offered this after they were asked.

If you don't know, you're on the hook for more.

Here's the deal as Bikeland sees it. When there's a disconnect as big as this between an OEM and their dealer network, there is a problem. Ducati has worked hard to build beautiful motorcycles, and they've hit the nail on the head with the 1098. It's sold out everywhere you go... Charging more than what is set out by the OEM is only going to cost the dealers business in the long run.

Bikeland contacted Ducati North America for comment. DNA states that they have worked very hard to get the message out that their bikes

now require far less maintenance than before. (We agree... just look at their marketing material). Ducati tells us that if they find out about dealers price gouging on service or charging rates that don't match their scale, the dealers "will hear about it".

Looking forward to servicing your 1098? Here are the DNA mandated shop charges inclusive of labour, but not including taxes

600 mile service - \$144.38

7500 mile service - \$ 256.88

15000 mile service - \$ 362.20

After 7500 mile Valve service ("Service A") - \$ 294.80

After 15000 mile Valve service ("Service A") - \$366.30

Caveat emptor!